

airhavn

by airlabs

USER GUIDE

<i>User guide</i>	1
<i>Before You Start</i>	2
Introduction to the AirHAVN PRO	2
Important Safety Warnings	3
Environmental	4
Performance	4
<i>Installation and operation</i>	5
Components	5
Installation	6
Operation	7
Service and maintenance Information	10
<i>Troubleshooting</i>	19
<i>Warranty Information</i>	21
Return and Warranty Policy	21
<i>Technical Specifications</i>	23
<i>Legal</i>	23
Simplified EU Declaration of Conformity	23

BEFORE YOU START

INTRODUCTION TO THE AIRHAVN PRO

Thank you very much for purchasing the AirHavn Pro. Nearly all of us are affected by poor air quality caused by airborne pollution and contamination: in traffic, in cities, outdoors, indoors, and inside the car. AirLabs' mission is to minimise air pollution exposure for people around the world and to drive down the number of air pollution related deaths. The AirHavn Pro in-building air cleaning unit floods rooms with large amounts of clean air, reducing exposure to airborne pollutants, contamination and viruses.

The three-stage layer filtration system uses a metal pre-filter, a high-grade electrostatic precipitator filter, to remove fine airborne particles, and an engineered nano-carbon filter, developed by AirLabs in partnership with the University of Copenhagen, to remove gas pollution.

AirHavn Pro creates a healthier indoor environment for all occupants by removing up to 99% of indoor airborne particles and gases. Particulate matter can include pollen, mould spores, soot, dander and can vary in size from PM₁₀ (10µm) and PM_{2.5} (2.5µm) down to particles below 0.1µm in diameter. It removes the smallest nanoparticles, thought to be the greatest risk to health, along with particles which carry bacteria or viruses. In addition to these particulates, the patented nano-carbon filter element will remove up to 95% of nitrogen dioxide, ozone and sulphur dioxide, along with many volatile organic compounds.

The AirHavn Pro is a portable stand-alone unit that requires no changes to the room's ventilation system or interior configuration and is easily installed within minutes. The AirHavn Pro is powered by mains electricity using the power lead provided.

Air is drawn into the AirHavn Pro, cleaned, and then specifically directed around the room providing clean air to anyone within the space. The design of the AirHavn Pro ensures that the clean air efficiently reaches all areas of the room. It is equipped with a powerful fan that is capable of delivering up to 705 cubic meters of clean air per hour.

Please read this user guide thoroughly before installation and operation and retain it for future reference.

Register your AirHavn Pro at www.airlabs.com/register.

IMPORTANT SAFETY WARNINGS

Your AirHavn Pro should only be installed and used as described in this User Guide. In addition to this, the following safety directions must be followed.

- Position the AirHavn Pro on a stable, level floor, making sure all 4 wheels are supporting the weight of the unit.
- Use only the power cable provided to power the unit in conjunction with a suitable mains power connection.
- Switch off the main power when the unit is not in use. Disconnect the power plug from the power outlet when you do not intend to use the unit for a longer period of time.
- Do not expose the unit to nearby objects that radiate heat to avoid damage to the unit.
- Do not place the unit in moist and humid environments, specifically do not place it in condensing environments. Also, please ensure that the AirHavn Pro is not exposed to dripping or splashing by liquids of any type. Do not touch the power plug with wet hands.
- Never submerge the AirHavn Pro, power supply or cable in water.
- Do not press foreign objects into the airflow outlets or inlets.
- Do not drop the AirHavn Pro or subject it to impacts.
- Please ensure the ventilation holes are not covered to avoid overheating and malfunction.
- Clean the AirHavn Pro according to the instructions. Ensure the AirHavn Pro is powered off before cleaning.

ENVIRONMENTAL

The AirHavn Pro and packaging consists of a cardboard outer box internally lined with polystyrene to protect the unit from any damage in transit. Please observe the local regulations regarding the disposal of packaging materials. You can dispose of your engineered nano-carbon filter in your regular household or commercial waste.

The AirHavn Pro is designed and manufactured with high quality materials and components, which can be recycled and reused. The crossed-out wheelie bin symbol on the product, literature, or packaging reminds you that all electrical and electronic products must be taken to separate collection at the end of their working life. Do not dispose of these products as unsorted municipal waste, check with your local waste authority for information about your nearest recycling point.

PERFORMANCE

Performance	Clean Air Delivery Rate	Air Exchanges	Removal Efficiency			Noise
	m ³ /hr	#/hr*	PM2.5	NO ₂	Ozone	dB
Speed 1	305	4	96	95	95	39
Speed 2	425	6	96	80	89	41
Speed 3	705	10	99	65	81	51

* Based on a room size of 30m² (with typical ceiling height of 2.4m)

INSTALLATION AND OPERATION

COMPONENTS

The following contents are included in the box.

1. AirHavn Pro main unit and filters

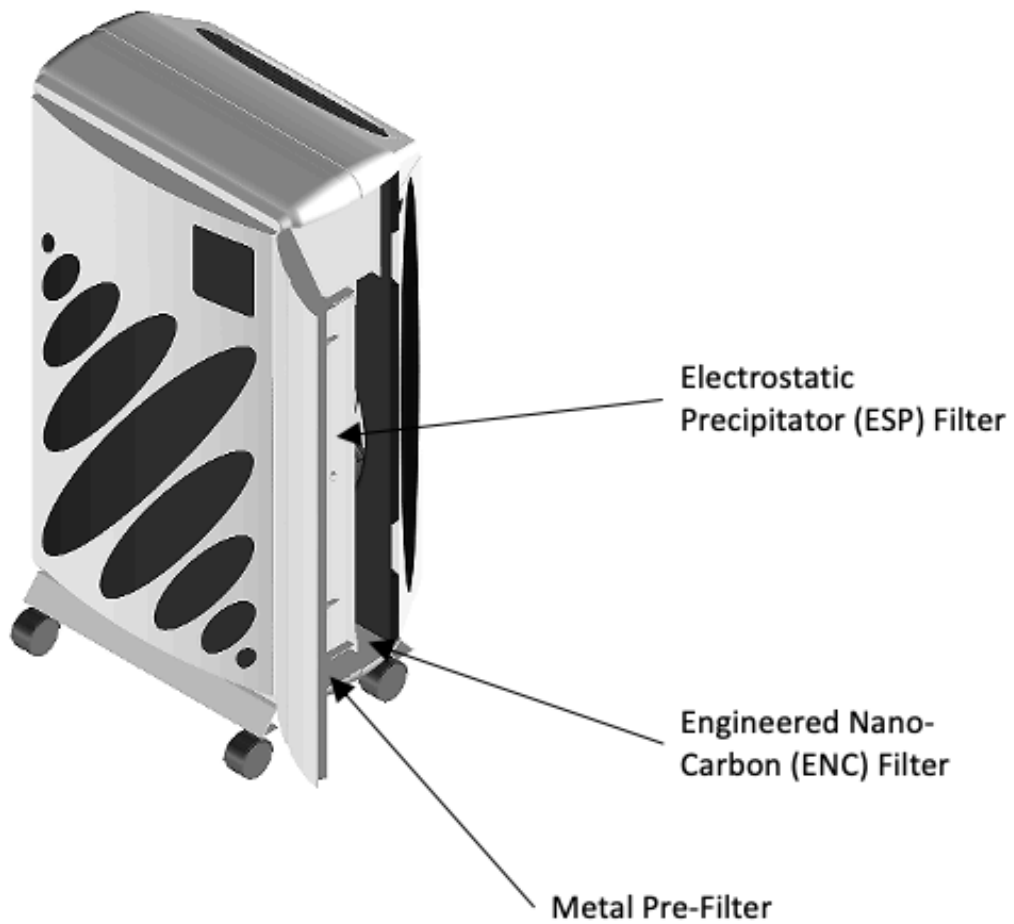

2. Mains power cable and plug
3. User Guide

INSTALLATION

The AirHavn Pro is designed for in-building use and can be situated anywhere within the internal space where clean air is required. For best performance results the recommended location is against a flat wall with the back of the unit facing the wall and the front of the unit facing out into the room.

During operation, air is drawn into the front of the AirHavn Pro and through the filter system. Clean air is delivered into and around the room from the two outlet vents on the sides of the unit and from the outlet vent on the top.

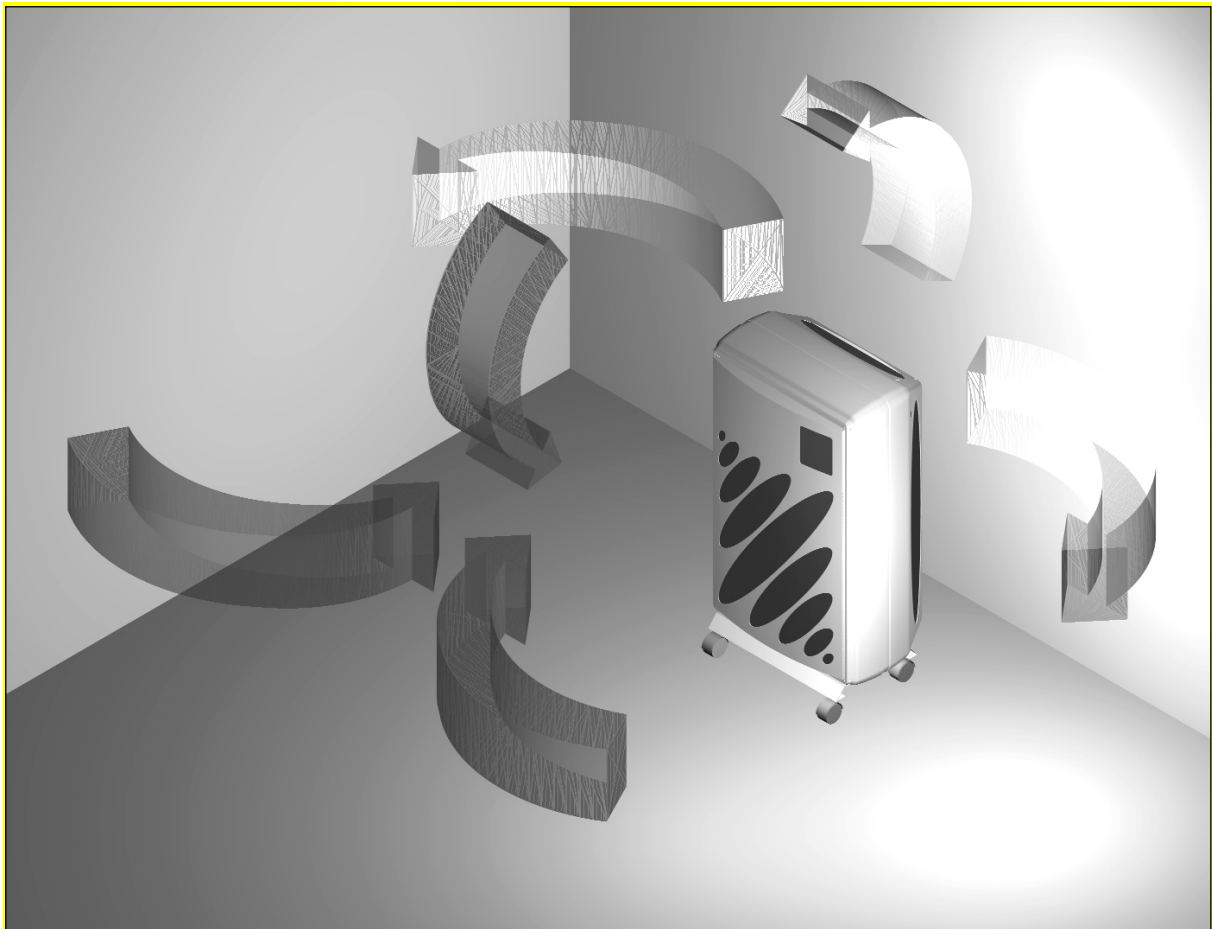

Do not obstruct the air flow of the unit by blocking any of the vents.

Commercial spaces are required to ensure a minimum standard of fresh air is introduced within enclosed spaces in order to provide a safe and healthy working environment for people within the room. These requirements must be adhered to regardless of using an AirHavn Pro to clean the air.

OPERATION

The AirHavn Pro is operated using the control panel on the front of the unit which also provides information on the status of the unit.

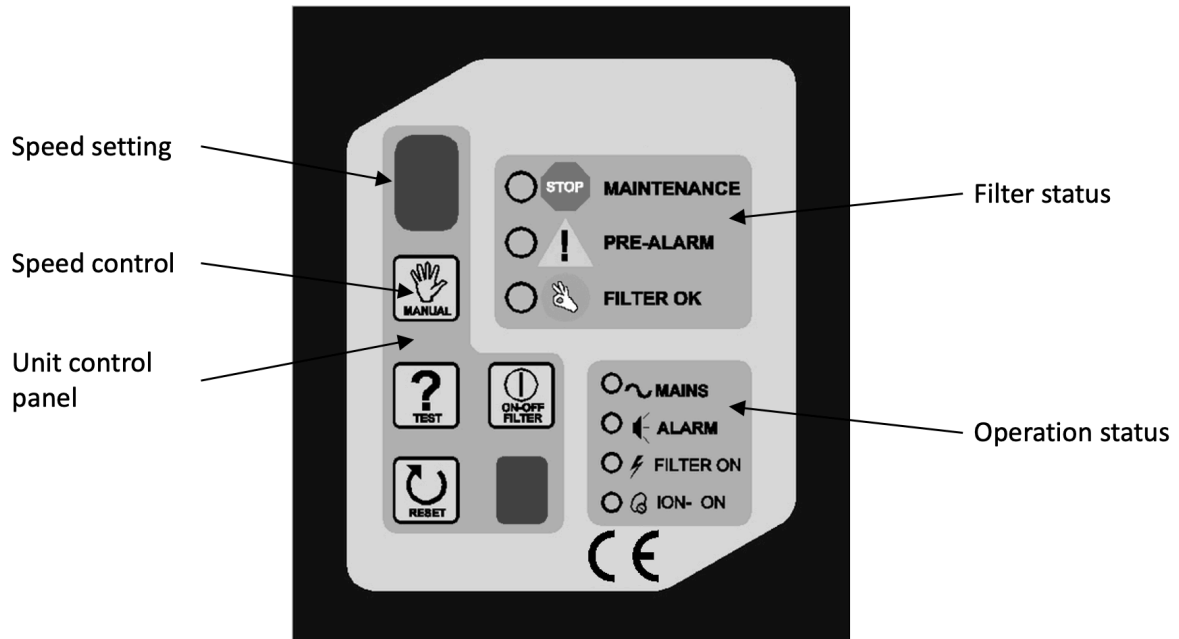

On/Off

To switch on the AirHavn Pro, just plug it in and the unit will power on in Standby mode with the speed setting showing 0.

To switch the AirHavn Pro off, just unplug it. The AirHavn Pro uses very little power while in Standby mode, but we still recommend unplugging it when not in use to save energy.

Note: When the AirHavn Pro is first switched on from new, or occasionally during operation, a sparking noise can be heard within the unit. This is the normal operation of the filter created by particle contamination on the electrostatic plates of the filter and is completely safe.

Operation Cycles and Modes

The MANUAL button allows the air flow to be modified manually (0-1-2-3) with setting 3 being the highest air flow speed. The setting is memorised and maintained even if there is a power failure.



The machine can be turned off by turning the speed control to 0 (fan off).

The TEST button will test the operation of the electrical system of the unit. The correct operation of the unit is indicated by the illumination of all the indicator lights on the control panel. If any lights do not illuminate, please review the troubleshooting section.



The ON-OFF FILTER button is for activating/deactivating the Electrostatic Precipitator Filter that performs the particle filtration function. It can be turned off in order to completely dry the ESP filtering unit after washing, or when only the fan and the gas filtration is required.



The RESET button is used to turn off the ALARM signal if the circuit protection device has tripped within the electrostatic cells. If the alarm persists after resetting, contact the service centre. For further details on the ALARM function – see Operation and Filter Status.



Operation Status

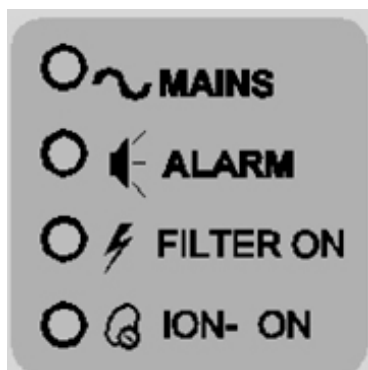

These four LED lights indicate the operating status of the unit:

- MAINS (green): Indicates that the unit is powered and switched on
- ALARM (red): Indicates a problem with the ESP filtration unit. The particle filtration function is not operating and the service centre should be contacted.
- FILTER ON (yellow): Indicates that filtering is on.
- ION- ON (yellow): Not used on this model.

Filter Status

The filtering status for the electrostatic precipitator filter is indicated by the three LED lights within the panel. If the filter is switched off using the ON-OFF FILTER button on the control panel then no LED lights will be displayed on the filter status panel. The pre-filter and engineered nano-carbon filter do not show a status indication.



- MAINTENANCE (red): The ESP filter must be cleaned and has been switched off. The ENC filter should be replaced at the same time.
- PRE-ALARM (yellow): The ESP filter is in need of cleaning but is still operating correctly.
- FILTER OK (green): The ESP filter is operating correctly.

SERVICE AND MAINTENANCE INFORMATION

THE AIRHAVN PRO MUST ALWAYS BE DISCONNECTED FROM THE POWER SUPPLY BEFORE ANY SERVICE OR MAINTENANCE IS CARRIED OUT.

Access to the service elements of the unit is via the access door on the right hand side of the unit. The door opening includes a finger pull mechanism and also incorporates a safety microswitch which cuts the power supply to the unit if the door is opened before the power is disconnected at the mains plug. The microswitch must not be modified for any reason, and must not be used in the closed position in any way so as to compromise safety. If the microswitch is broken the unit will stop functioning. Contact AirLabs support for the replacement of this component.

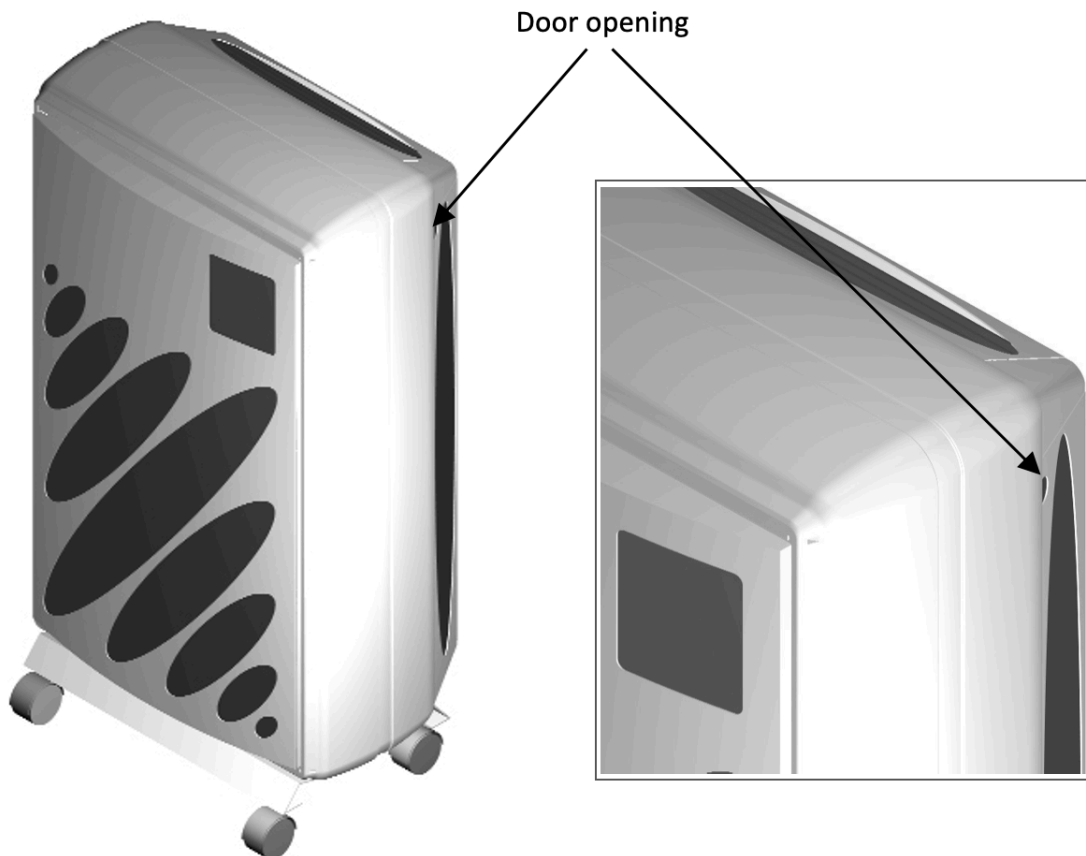

The AirHavn Pro uses 3 stages of filter systems to provide clean air within an indoor space. The 3 filters used in these stages are defined below and require periodic cleaning and replacement. The control panel of the unit will indicate when the filter system needs servicing – see Filter Status section for more information:

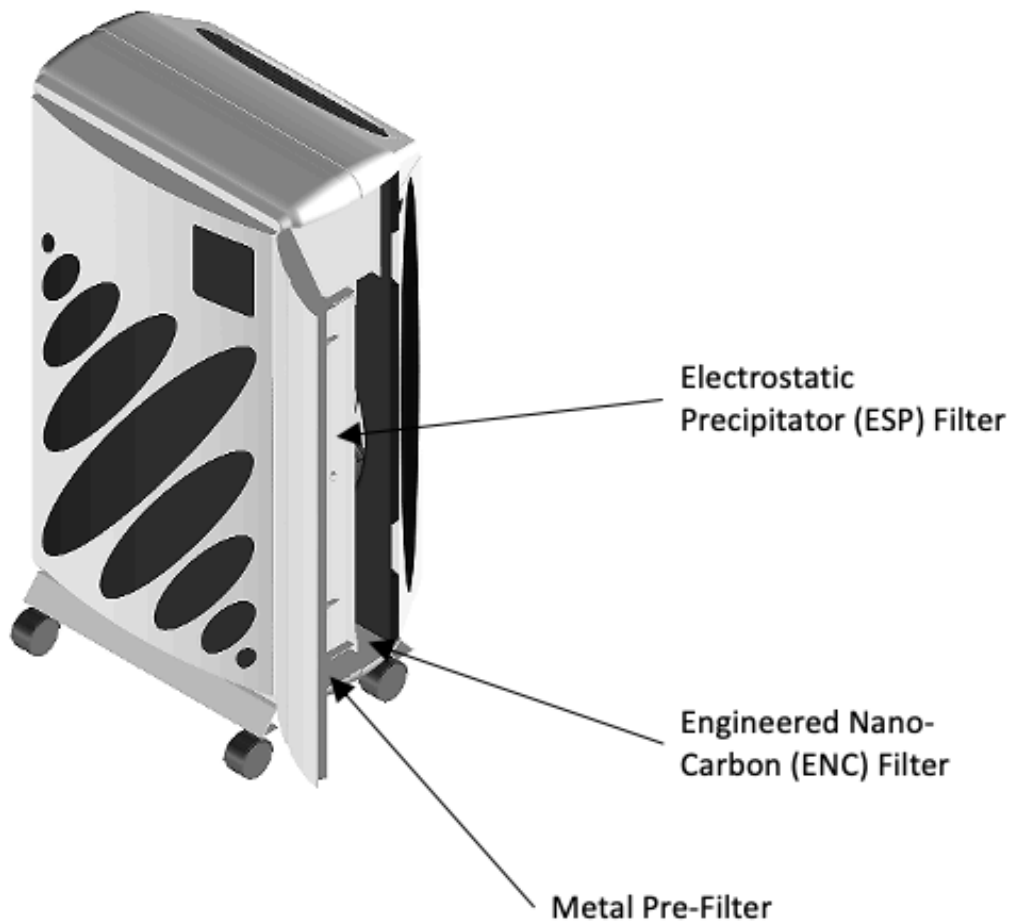

Metal Pre-Filter

The metal pre-filter is designed to trap larger particles present in the air and for creating a uniform airflow into the next stage of filtering.

During operation, the metal pre-filter must always be inserted correctly into the location slot.

During maintenance, the filter must be handled with care to prevent damage.

Electrostatic Precipitator (ESP) Filter

The filter works by using a high voltage power source to apply an electrical charge to any particles within the airflow and then trap those charged particles on collection plates within the unit. Particles can include pollen, mould spores, soot, dander and can vary in size from PM₁₀ and PM_{2.5} down to particles below 0.1µm in diameter.

The ESP filter is fully insulated from the rest of the unit by high-quality ceramic insulators and connects to the power supply with a contact terminal strip when the unit is inserted correctly into the seating location.

Engineered Nano-Carbon (ENC) Filter

The ENC filter is designed to remove harmful gases from the air including Ozone, Nitrogen Dioxide (NO₂), Sulphur Dioxide (SO₂) and Volatile Organic Compounds (VOCs). The filter material is held in place within a metal frame

Filter Maintenance

To carry out maintenance of the filter systems it is necessary to remove all the filter units from the main body of the AirHavn Pro.

When removing the filter systems from the unit the user should wear proper personal protective equipment (PPE) including grade N95 dust mask, goggles over the eyes, and gloves. At the end of the cleaning procedure, remove and dispose of PPE and wash hands.

The filter units are removed individually by sliding out through the access door opening.

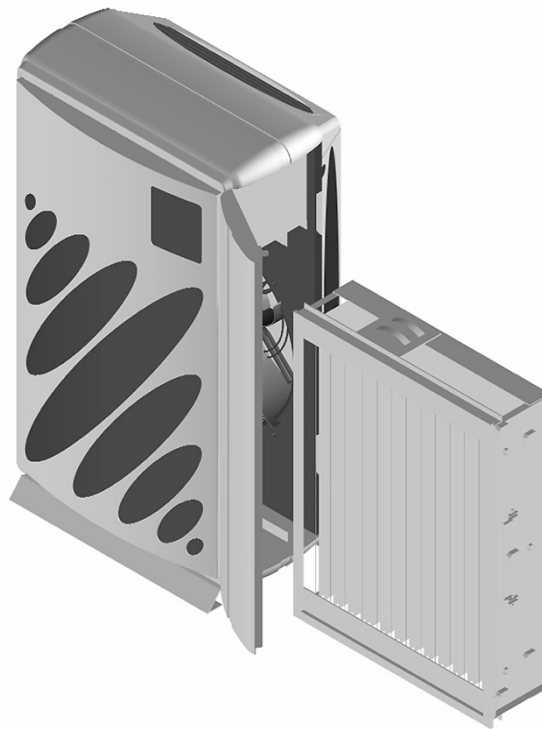

The ESP filter and metal pre-filter can be maintained through regular cleaning.

Cleaning Process: ESP & Metal Pre-Filter

Equipment required:

- 1) Two plastic or stainless steel trays with minimum dimensions L-600mm x W-500mm x D-300mm.
 - a) Stage 1 tray used for washing with the base raised 2-3 cm to separate the filter from the removed contaminant.
 - b) Stage 2 tray used for neutralising any residual washing detergent
- 2) Non-corrosive detergent for washing the ESP filter. See www.airlabs.com for a list of suitable cleaning detergents.
- 3) A hose pipe for rinsing the filters.
- 4) Acetic acid such as household vinegar.

Prepare the stage 1 tray with warm water (max 45°C). Dilute the detergent in the proportions indicated on the label of the detergent itself.

Prepare the stage 2 tray with water and vinegar diluted at a ratio of 1 litre of acetic acid for every 20 litres of water.

ESP Filter Cleaning

Slide the ESP filter from the unit and proceed to clean the filter as follows:

1. Immerse the filter cell in the stage 1 tray with the detergent and soak until the dirt is dissolved.

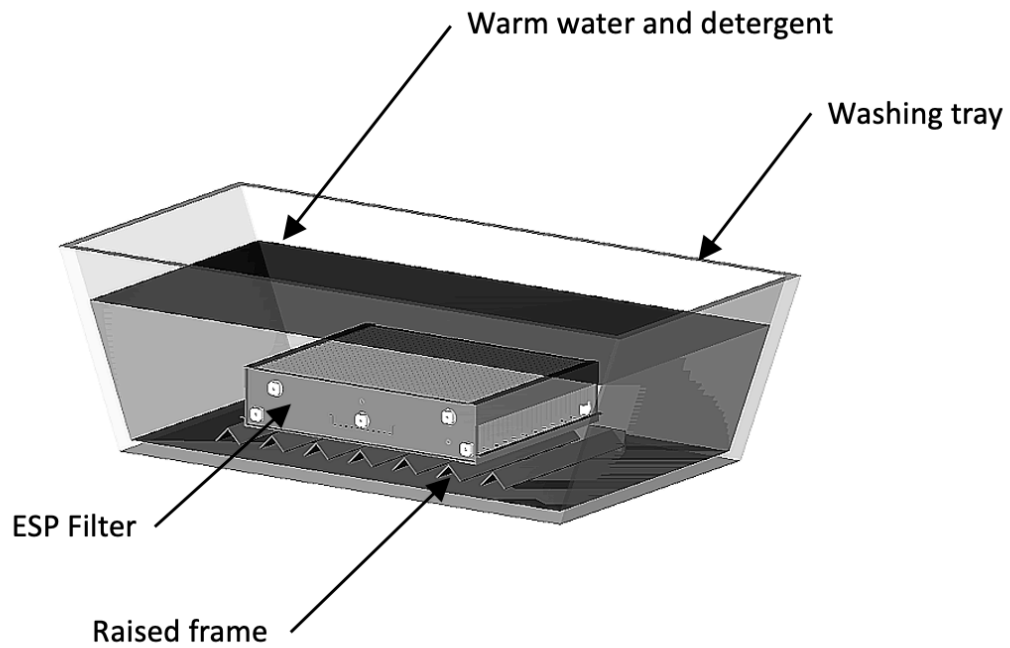

2. Remove the electrostatic cell and rinse thoroughly with running water, taking care not to break the ionisation wires.

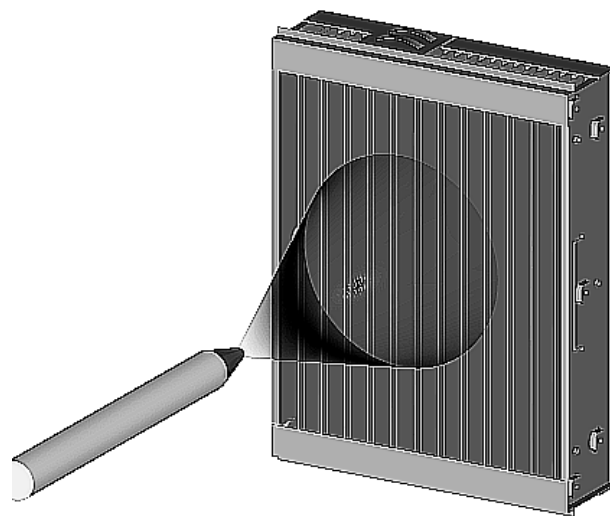

3. Immerse the cell in the stage 2 tray containing the water and vinegar and leave to soak for 5-10 minutes.
4. Remove the cell and leave it to dry in a warm place, keeping it raised from the ground by wooden blocks (unit can be dried in an oven with a maximum temperature of 60°C).

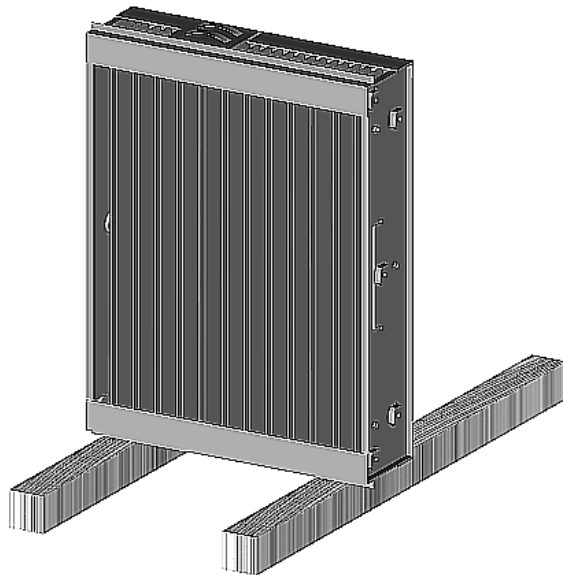

5. Examine the state of the ionisation wires, stretching them slightly to check their mechanical strength. Use a cotton flock and methylated spirits to remove any residual traces of dirt.
6. Ensure that the cell is thoroughly clean and dry before reinstalling it.

Metal Pre-Filter Cleaning

Remove the metal pre-filter from the unit and use a vacuum cleaner to remove any dust deposited on the surface. Then proceed with washing as follows:

1. Immerse the pre-filter in the stage 1 tray containing the detergent diluted in warm water and leave to soak for about half an hour.
2. Remove the pre-filter from the tray and rinse thoroughly with water.
3. Leave to dry in a warm ventilated environment.

ENC Filter

The ENC filter cannot be cleaned and must be replaced with a new filter at the same time as the ESP filter is cleaned.

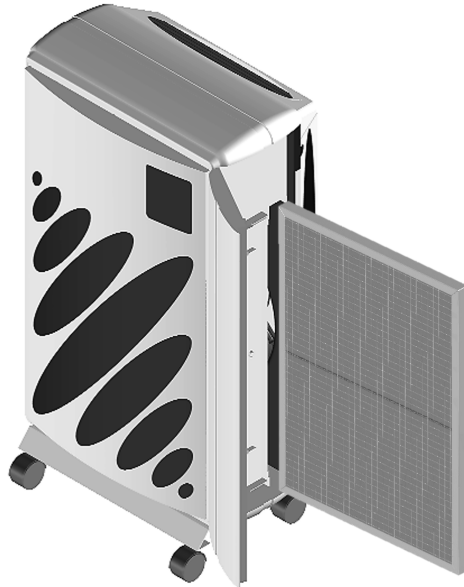

The ENC filter is located behind the ESP filter and is removed from the unit by sliding out the metal holding frame.

The filter retaining bars can be removed to provide access to the filter material for replacement. The new filter material should be placed in the frame and the retaining bars reassembled.

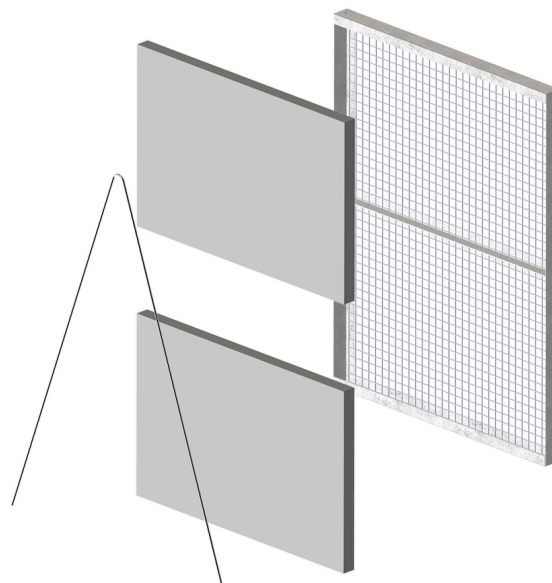

Filter Inspection

The condition of the filters must be inspected every time they are washed so as to ensure correct operation and performance of the AirHavn Pro.

Filter	Inspection	Fault	Operation
Metal Pre-Filter	Metal frame and filter mesh	Damage to the frame or mesh. Filter wires protruding from the filtration mesh	Replace the filter. Please contact support via the www.airlabs.com website.
ESP Filter	Ionisation wires	Broken wire	Ionisation wire must be replaced. Please contact support via the www.airlabs.com website.
		Surface roughness with material deposits	Clean the wire with cloth soaked in alcohol cleaning solution or replace the wire. Please contact support via the www.airlabs.com website.
	Ceramic insulators	Material deposits and dirt	Repeat the washing process until clean
		Broken insulator or sign of crack	Insulators must be replaced. Please contact support via the www.airlabs.com website.
High voltage contact terminal strip	High voltage spark erosion or burning	High voltage contact terminal must be replaced. Please contact support via the www.airlabs.com website.	
ENC Filter	Metal frame	Damage to the frame	Replace the filter frame. Please contact support via the www.airlabs.com website.
	Filter material and containment bag	Damage to the containment bag	Replace the filter. Please contact support via the www.airlabs.com website.

Cleaning The Unit Housing

Disconnect the unit from the power supply.

To clean the outside, use a cloth and neutral detergent.

Use a brush with soft bristles to clean the air outlet fins.

To clean the inlet grill, use a vacuum cleaner with a brush attachment.

Electronic Circuit Protection Devices

The electronic circuit is provided with a series of protection devices that automatically disconnects the high voltage power supply if a malfunction is detected. There is a thermal fuse inside the unit that will cut the power supply if a short circuit occurs within the power system.

Blown fuses must be replaced with the correct rated fuse and must be carried out by the AirLabs authorised service team.

TROUBLESHOOTING

<p>The AirHavn Pro does not turn on</p>	<p>Check that there is power from the outlet you are using and the wall switch is on. Make sure the power cable is connected to the unit. Make sure the fuse in the plug has not blown. If the AirHavn Pro still does not turn on, please contact support via the www.airlabs.com website.</p>
<p>A sparking sound can be heard while the unit is running</p>	<p>Occasionally, or when the unit is new, particle contamination in the ESP filter can cause a short circuit between the wires and plates within the ESP. This is normal and completely safe. If the sparking continues, turn off the AirHavn Pro at the wall socket and inspect the ESP filter for obvious signs of contamination. If necessary, undertake the ESP cleaning process.</p>
<p>The AirHavn Pro turns off momentarily</p>	<p>The AirHavn Pro incorporates circuit protection should high levels of particle contamination cause a short circuit within the ESP filter. The unit will restart automatically.</p>
<p>The Alarm is activated</p>	<p>Power off the unit at the wall and power on again. If the problem persists, please contact support via the www.airlabs.com website.</p>
<p>The AirHavn Pro fan stops running</p>	<p>Power off the unit at the wall and power on again. If the problem persists, please contact support via the www.airlabs.com website.</p>
<p>The fan runs without any speed indication on the display</p>	<p>Please contact support via the www.airlabs.com website.</p>
<p>Unable to change the fan speed</p>	<p>Power off the unit at the wall and power on again. If the problem persists, please contact support via the www.airlabs.com website.</p>
<p>The fan is making a louder noise than usual</p>	<p>Remove the filters and check for anything impacting the fan. If the noise persists, please contact support via the www.airlabs.com website.</p>
<p>One or more LED lights do not illuminate when the TEST button is pressed.</p>	<p>Please contact support via the www.airlabs.com website.</p>
<p>More than one of the filter efficiency LED light is illuminated at the same time</p>	<p>Please contact support via the www.airlabs.com website.</p>
<p>The letter 'P' or 'N' on the display is shown</p>	<p>Disconnect the power supply and wait 5-10 seconds before connecting it back in.</p>

Alarm Notifications

TYPE OF ALARM	CAUSE	OPERATION
yellow LED on PRE-ALARM or letter F on the display	ESP filter needs to be cleaned	Carry out normal maintenance. See service information.
yellow LED on PRE-ALARM	ESP filter is not completely clean	If small areas of contamination remain, repeat the washing process again. See service information.
yellow LED on PRE-ALARM	ESP filter damp	Dry the filter cell thoroughly and particularly in the around the insulators using an absorbent cloth or run the unit with the filter turned off.
yellow LED on PRE-ALARM	ESP filter is not fully rinsed	There may be detergent on the insulators; the filter cell must be thoroughly rinsed again.
yellow LED on PRE-ALARM	Small particle bodies trapped between the collection plates	The particles deposited on the plates must be removed. See service information.
red LED on MAINTENANCE	ESP filter must be cleaned. Filter will be switched off.	Carry out normal maintenance as soon as possible. See service information.
red LED on MAINTENANCE and ALARM	ESP filter ionisation wire is broken	The wire must be removed and replaced immediately by a qualified support technician.
red LED on MAINTENANCE and ALARM	ESP filter short circuited due to damaged collection blade	The blade must be straightened (call a service technician)
red LED on MAINTENANCE and ALARM	ESP filter short circuited by contamination trapped between the plates	Contamination must be removed using a cloth soaked in alcohol, taking care not to break the ionisation wires
letter F on the display	Ionisation wires dirty or oxidised	Clean the wires with a cloth soaked in alcohol; if the problem persists, the wires must be replaced

WARRANTY INFORMATION

RETURN AND WARRANTY POLICY

The AirHavn Pro has a warranty period of **2 years** from the original purchase date applicable to any defects in the materials or running of the product. In such cases, you are entitled to a repair or replacement, depending on the defect found. You will need to contact support via the www.airlabs.com website to obtain an RMA (Return Merchandise Authorization).

The following information will be required for the RMA:

- Model number and serial number of the failed unit
- Full description of Apparent Damage or Failure
- Component description (if claiming for a specific component rather than the main unit indicate the model and serial number of the component)
- Date of claim

We will then supply you with an RMA claim number which can be used to track the progress of the claim.

If the RMA claim is approved, AirLabs will provide information on the repaired/replaced unit being delivered back to you. The RMA Claim Form will be updated to reflect this information.

The unit model and serial number are shown on the identification label behind the access door.



The label provides the identification and technical data of the unit.

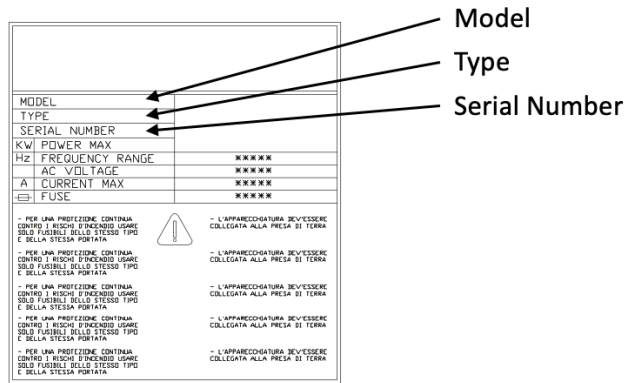

TECHNICAL SPECIFICATIONS

Power consumption	125 W at highest speed
Voltage input	240v @ 50/60 Hz
Dimensions H x W x D	840 x 468 x 303mm
Weight	30kg



LEGAL

SIMPLIFIED EU DECLARATION OF CONFORMITY

Hereby, AirLabs Limited declares that this product is in compliance with Directives 2006/42/EC, 2004/108/EC and 2006/95/EC. The full text of the EU declaration of conformity is available on request.

AirLabs Limited
88 Baker Street
London, W1U 6TQ

www.airlabs.com